

Six Foot Picnic Table Assembly

FP1011 (Instructions for Assembly)

Hardware supplied: 20 pieces 2 1/2" (#10) square head stainless steel screws
12 pieces 3 1/2" carriage bolt with 7/16" flange nuts
12 pieces acorn nut
4 pieces 3" lag screw with 7/16" washers
1 piece # 2 square head driver bit

Tools required: 1/4" drill bit (needs to be 6" or longer)
variable speed drill or screw gun (cordless drill is fine)
7/16" socket or impact wrench
hammer or rubber mallet

REFER TO ATTACHED FIGURES 1 THROUGH 3

1. Lay table top (top side down) on a **FLAT** surface.
2. Legs are installed to the **inside** of the 2 x 4 table top support at the pre-drilled top hole labeled "A" on the diagram (fig.1). Insert the 3 1/2" carriage bolt through the 2 x 4 support underneath the table top, then through the 4 x 6, and tap into place with a hammer. Insert washer and nut on the counter bored side of table leg and tighten with a socket wrench. **HAND TIGHTEN ONLY.** Firmly tightening at this point will cause the bench supports in step #3 to not line up properly. Repeat procedure for the other 3 legs.
3. **Horizontal bench support installation.** Align holes in the bench support with the holes, labeled position "B" in (fig.1), on the 2 table legs (on the inside). Insert the 3 1/2" carriage bolt through the 2 x 6, then through the 4 x 6 table leg. Make sure the aluminum is facing up, and to the inside. It is helpful if you only do 1 bolt on each side, this makes it easier to line up the holes. Tap through with a hammer. Place washer and nut on the counter bored side and tighten with a socket wrench. **HAND TIGHTEN ONLY.** Repeat procedure for other bench support. Now firmly tighten all 12 nuts beginning at position "A". Cover all nuts with acorn nuts.
4. Position benches approximately 11 3/4" off the ground and align with bench support until gap as shown in figure 1 is achieved. Screw 2 pieces 2 1/2" stainless steel screws through bench supports into each bench end at position "C" in (fig. 1). Repeat procedure for other bench.
5. Align angle braces into position as shown in figure 2. Place washer onto 3" lag screw and insert into pre-drilled hole at position "D". **DO NOT ATTACH LAG SCREWS INTO POSITION "E" FIRST.** Lightly tap lag screw into the angle brace with a hammer. Tighten until snug with a socket wrench. A slight gap will form between angle brace and the horizontal seat support at position "E". **DO NOT OVERTIGHTEN LAG SCREWS.** Over tightening will cause lag screws to strip out their holes and not grip properly. Next push the angle brace down to meet the 2 x 6 and align with the counter bored hole at position "E". Insert and tighten 3" lag screw and washer into brace at position "E". Repeat procedure other angle brace.
6. Install middle cross brace between the 2 angle braces. Screw 2 pieces 2 1/2" stainless steel screws into the side of the cross brace at position "F" in (fig. 2). Make sure to screw through the side of the cross brace into the side of the angle brace. **DO NOT SCREW THROUGH THE 2 X 6 INTO THE END OF THE CROSS BRACE.** Repeat for the other end.
7. Flip table over and position on a flat surface where desired.
8. Screw 1 piece 2 1/2" stainless steel screws through the top of the seat assembly into the horizontal seat support below at position "G". Repeat on the other end, and then both ends of the other seat assembly.

End View

Figure 1

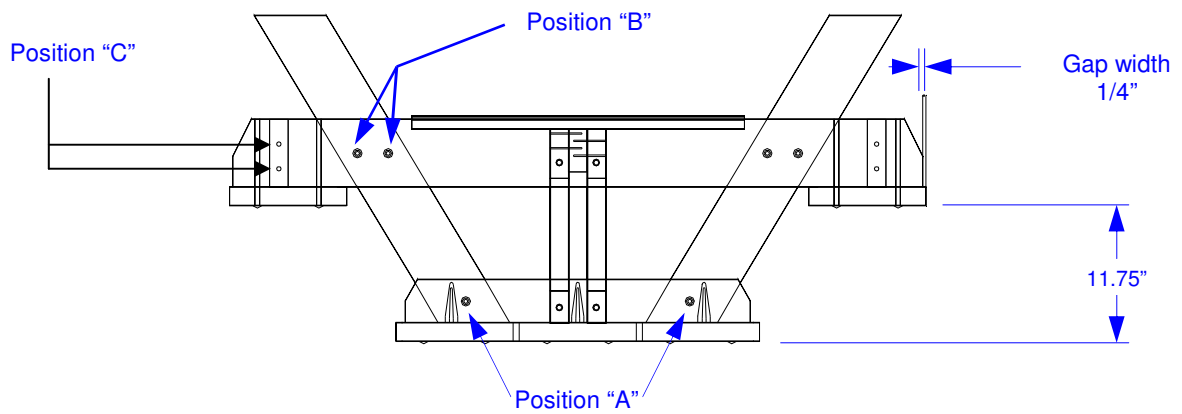

Side View

Figure 2

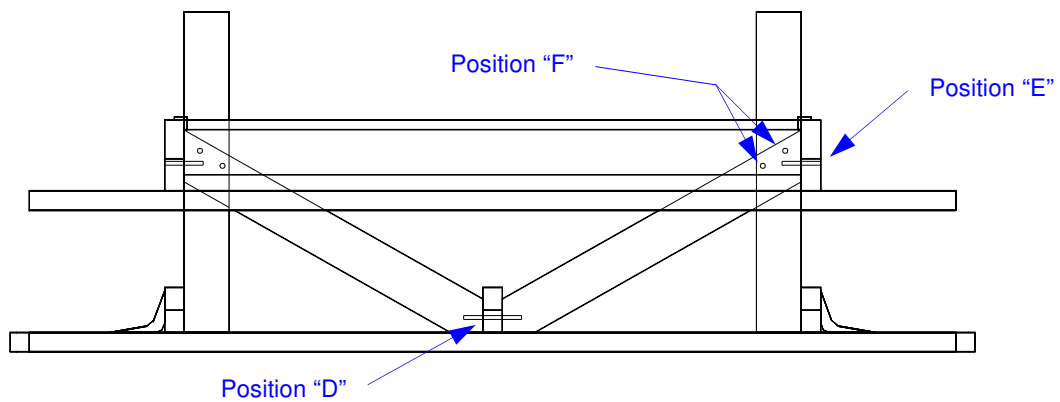

Assembled View

Figure 3

