

**Package Contents**

Hardware

- 24 stainless Square Pan head screws
- 1 # 2 square driver bit

Supports

- 2 step risers (PLS48)
- 2 step treads
- 2 1" plugs

**Maintenance**

Our products clean up with mild soap and warm water.

**Tools Needed**

- Variable speed drill
- driver bit (supplied)
- screw driver

*\*Note: for extra support, it is recommended that sand or water be added into each riser. Play sand works great. Add sand through the hole in the bottom of each riser, then plug the hole with the plug provided. If water is used, the same procedure can be used, however, due to freeze/thaw issues, do not over-fill the riser. Fill each support with enough weight to suit your personal needs.*

**Assembly Procedure**

- Step 1...**Place one pre-assembled step tread upside down so the rounded trim is facing you.
- Step 2...**Position one support into left corner making sure rounded trim is facing front of finished step, fasten with (6) screws (see figure A). Repeat process at right corner.
- Step 3...**Repeat steps 1-3 to fasten second tread to complete assembly.

**Assembly Drawing**

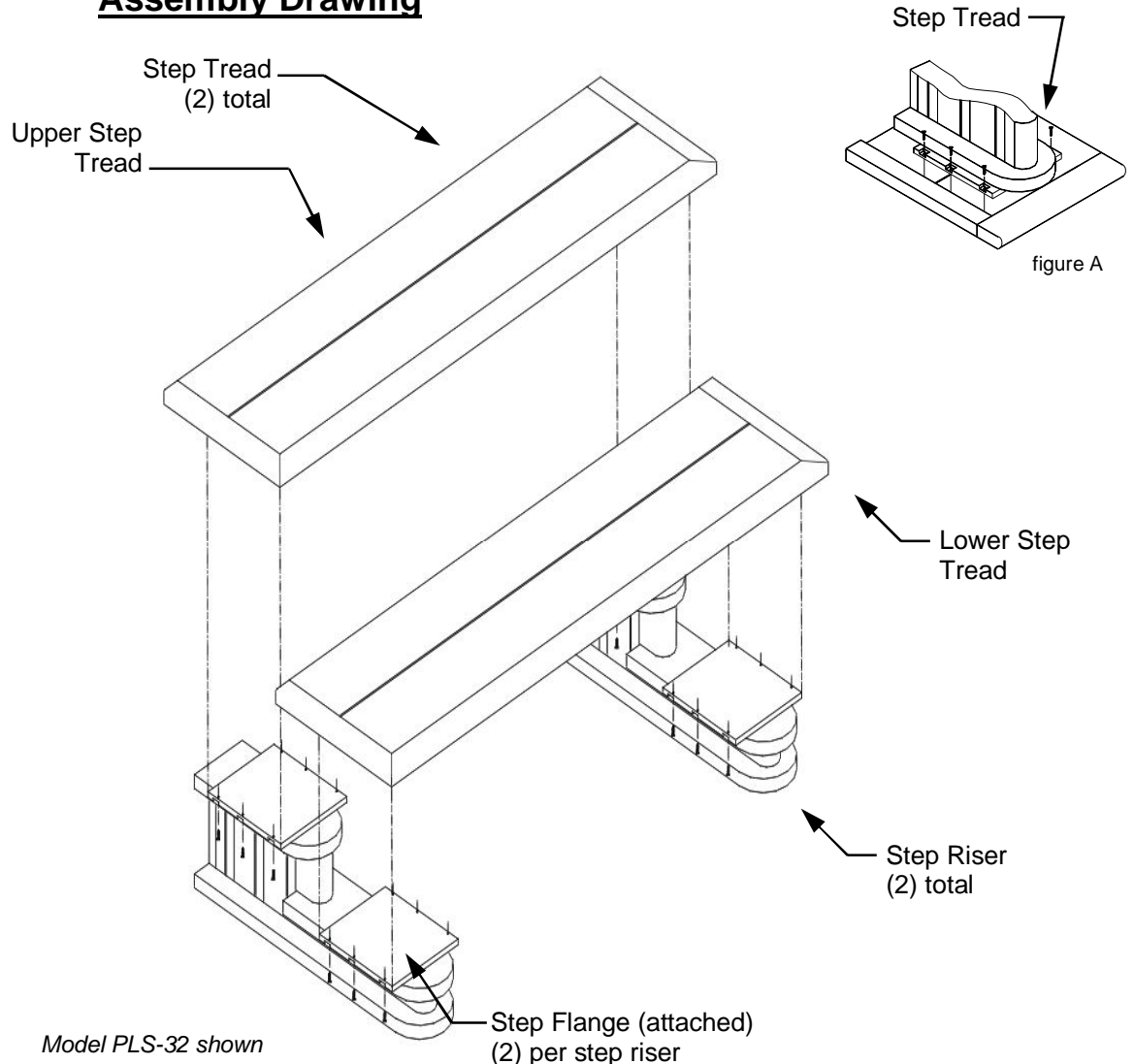

Model PLS-32 shown



Bright Idea Shops LLC.  
 Plastic Lumber Works  
 540 South Main Street Building 7  
 Suite 714  
 Akron, Oh 44311  
 Phone: 330-258-0168  
 Fax: 330-258-0167  
 www.brightideashops.com